

DESCRIPTION	DIMENSIONS IN INCHES (A x B x C)	PART NUMBER	CFM	EFF. @ 0.3"	INCHES W.G.
VGXL99-610x610x292-OU-PS	24 x 24 x 11-1/2	855017004	1910	99.99	0.8
VGXL99-595x595x292-OU-PS	23-3/8 x 23-3/8 x 11-1/2	855017005	1770	99.99	0.8
VGXL99-610x305x292-OU-PS	24 x 12 x 11-1/2	855017006	840	99.99	0.8
VGXL99-595x289x292-OU-PS	23-3/8 x 11-3/8 x 11-1/2	855017007	790	99.99	0.8

- MATERIALS NOTES:**
1. FILTER MEDIA: MICRO-GLASS FIBER / ACRYLIC RESIN BINDER
 2. FRAME MAT'L: PLASTIC
 3. SEALANT MAT'L: FIRE RESISTANT / PHOSPHORUS FREE TWO PART POLYURETHANE
 4. GASKET MAT'L: NON-FLOWING URETHANE
 5. ACCESSORIES: EXTRACTION CLIPS

- TESTING NOTES:**
1. EACH FILTER SHALL BE TESTED FOR EFFICIENCY IN ACCORDANCE WITH IEST-RP-CC-007.
 2. MUST TEST FILTERS WITH PAO ONLY.

FILTER SPECIFICATIONS:

PLEAT DEPTH (IN): 24mm
 EFFICIENCY (%): SEE TABLE
 MAX. OPERATION TEMP: 175°
 MAX. REL. HUMIDITY (%): 99%

FRAME TOLERANCES:

LENGTHS (A , B) = +0.00, -0.070"
 DEPTH (C) = +0.060", -0.040"

HALF SIZE

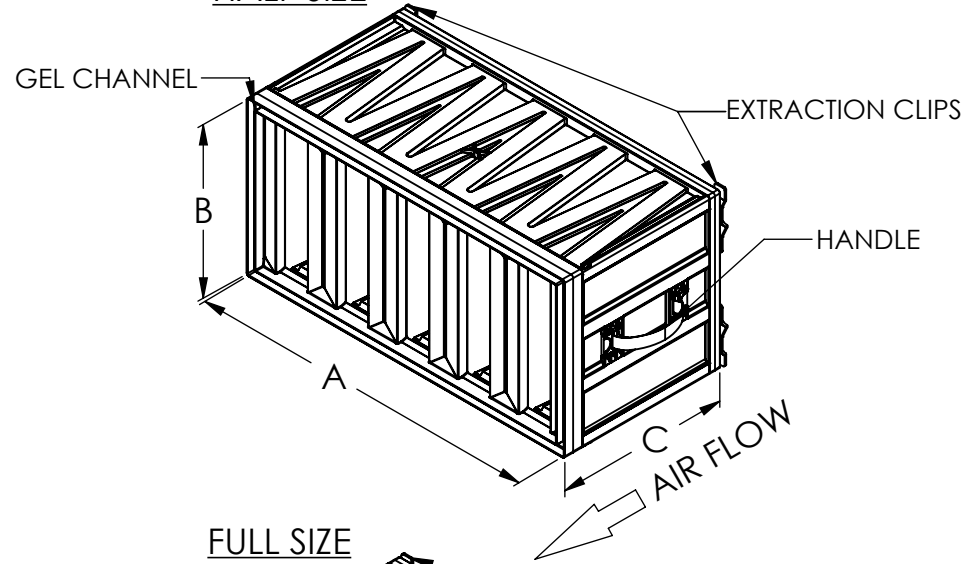

FULL SIZE

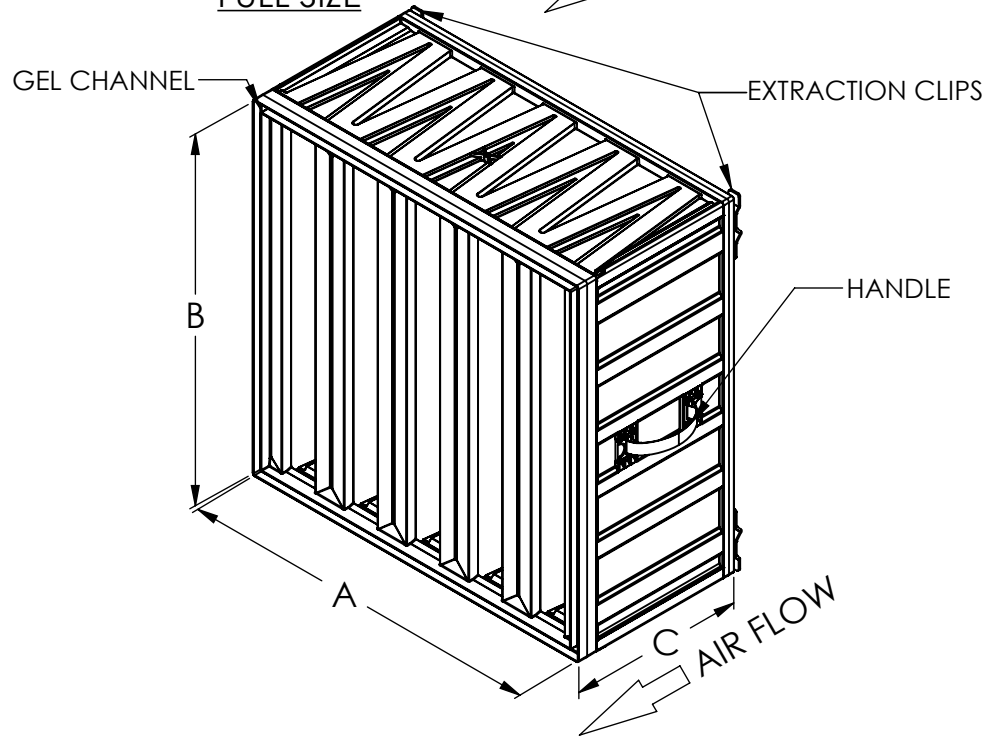

CUSTOMER APPROVAL BLOCK			
YOUR APPROVAL OF THIS PRINT AUTHORIZES CAMFIL USA INC. TO PROCEED WITH MATERIAL PROCUREMENT, TOOLING AND PRODUCT FABRICATION. ANY CHANGES MADE AFTER APPROVAL MAY INCUR FURTHER EXPENSES TO THE CUSTOMER.		© Camfil USA Inc.	
<input type="checkbox"/> OK AS IS <input type="checkbox"/> SEND REVISED DWG.		DESCRIPTION ABSOLUTE VG PLASTIC W/ EXTRACTION CLIPS	
SIGNATURE/DATE: _____		SHEET 1 OF 1	
COMPANY NAME: _____		DRAWING NUMBER 512137	
APPROVED BY: SM	DATE: 7/10/2024	DRAWN BY: BB	DATE: 7/10/2024
		REV.	